

### VDS Series Small Variable Volume Vane Pump

8cm<sup>3</sup>/rev  
15 ℓ  
7MPa

#### Features

##### ① High efficiency operation with minimal power loss

All the performance of the original new VDR series mechanisms combines with precision machining for a pump that minimizes power loss, especially at full cut-off.

##### ② Quiet operation

Journal bearings with a proven record on IP pumps plus new suction and discharge port configurations reduce operating noise and

deliver quiet operation with minimal vibration, even in the high-pressure range.

##### ③ Compact and simple design, easy operation

Compact and quiet, VDS Series variable vane pumps are economical and easy to handle. A simple design allows use in a wide range of hydraulic systems.

##### ④ Precise characteristics, prompt response

Prompt response at both ON-OFF and OFF-ON ensures instantaneous, stable, high-precision operation.

##### ⑤ Solidly built for high efficiency and long life

VDS Series pumps are built to last, with a design that incorporates years of NACHI experience and know-how. Specially selected materials and skilled workmanship provide outstanding durability along with stable, high-efficiency operation.

#### Specifications

Model No.	Capacity cm <sup>3</sup> /rev	No-load Discharge Rate ℓ/min				Pressure Adjustment Range MPa {kgf/cm <sup>2</sup> }	Allowable Peak Pressure MPa {kgf/cm <sup>2</sup> }	Revolution Speed min <sup>-1</sup>		Weight kg
		1000min <sup>-1</sup>	1200min <sup>-1</sup>	1500min <sup>-1</sup>	1800min <sup>-1</sup>			Min.	Max.	
VDS-0A(B)-1A1-10						1 to 2 {10.2 to 20.4}				
“ -1A2 “	8.3	8	10	12.5	15	1.5 to 3.5 {15.3 to 35.7}	14 {143}	800	1800	A : 6.5 B : 4.5
“ -1A3 “						3 to 7 {30.6 to 71.4}				

#### ● Handling

- The direction of rotation for this pump is clockwise (rightward) when viewed from the shaft side.
- Drain piping must be direct piping up to a point that is below the tank fluid level, and back pressure due to pipe resistance should not exceed 0.03MPa.
- When adjusting pressure, pressure is increased by clockwise (rightward) rotation of the adjusting screw and decreased by counterclockwise (leftward) rotation.
- When adjusting the flow rate, the flow rate is decreased by clockwise (rightward) rotation of the adjusting screw and increased by counterclockwise (leftward) rotation. The graph on the right provides general guidelines for the relationship between the rotation angle of the flow rate adjusting screw and the no-load discharge rate.
- Factory Default P-Q Settings (Standard Model)
  - Flow Rate Setting = Maximum flow rate for model as indicated in the catalog
  - Pressure Setting = Pressure shown in table below

Factory Default Pressure Settings MPa{kgf/cm <sup>2</sup> }
1 : 2.0 {20.4}
2 : 3.5 {35.7}
3 : 7.0 {71.4}

However:  $Q=q \times n \times 10^{-3}$

Q : No-load Discharge Rate (ℓ/min)

q : Capacity (cm<sup>3</sup>/rev)

N : Revolution Speed min<sup>-1</sup>

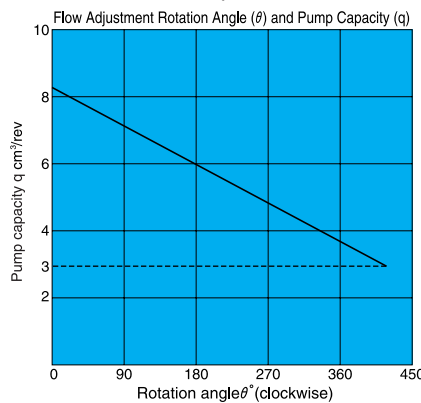

The values indicated above are at maximum pump discharge volume with the flow volume adjusting screw at the 0° position.

The broken line shows the flow volume adjustment range lower limit value.

#### ⑥ Thrust Screw

The thrust screw is precision adjusted at the factory during assembly. Never touch the thrust screw. See callout 9 in the cross-section diagram on page B-4.

#### ⑦ Initial Operation

Before operating the pump for the first time, put the pump discharge side into the no-load state and then repeatedly start and stop the motor to bleed all air from inside the pump and the suction piping. After confirming that the pump is discharging oil, continue the no-load operation for at least 10 minutes to discharge all the air from the circuit.

#### ⑧ For the hydraulic operating fluid, use an R&O type and wear-resistant type of ISO VG32 to 68 or equivalent (viscosity index of at least 90). Use hydraulic operating fluid that provides kinematic viscosity during operation in the range of 20 to 150mm<sup>2</sup>/s.

#### ⑨ The operating temperature range is 15 to 60°C. When the oil temperature at startup is 15°C or less, perform a warm-up operation at low pressure until the oil temperature reaches 15°C. Use the pump in an area where the temperature is within the range of 0 to 60°C.

(Continued on following page)

- 10 Suction pressure is -0.03 to +0.03MPa (-0.3 to +0.3kgf/cm<sup>2</sup>), and the suction port flow rate should be greater than 2m/sec.
- 11 Avoid pulley, gear, and other drive systems that impart a radial or thrust load on the end of the pump shaft. Mount the pump so its pump shaft is oriented horizontally.
- 12 Provide a suction strainer with a filtering grade of about 100 μm (150 mesh). For the return line to the tank, use a 25 μm line filter.
- 13 Manage hydraulic operating

fluid so contamination is maintained at class NAS10 or lower. Take care to avoid contamination with water or other foreign matter, and watch for discoloration. Whitish fluid indicates that air has contaminated the fluid, and brownish fluid indicates the fluid is dirty.

- 14 Contact your agent about using water- and glycol-based hydraulic operating fluids.
- 15 At startup, repeat the inching operation (start-stop) to bleed air from the pump and pipes.

16 Equip an air bleed valve in circuits where it is difficult to bleed air before startup. See page C-13 for more information.

17 To ensure proper lubrication of the pump's rubbing surfaces, supply oil to the interior of the pump before starting operation.

18 When centering the pump shaft, eccentricity with the motor shaft should be no greater than 0.05mm.

The angle error should be no greater than 1°.

## Understanding Model Numbers

VDS - O \* - 1 A \* - 10

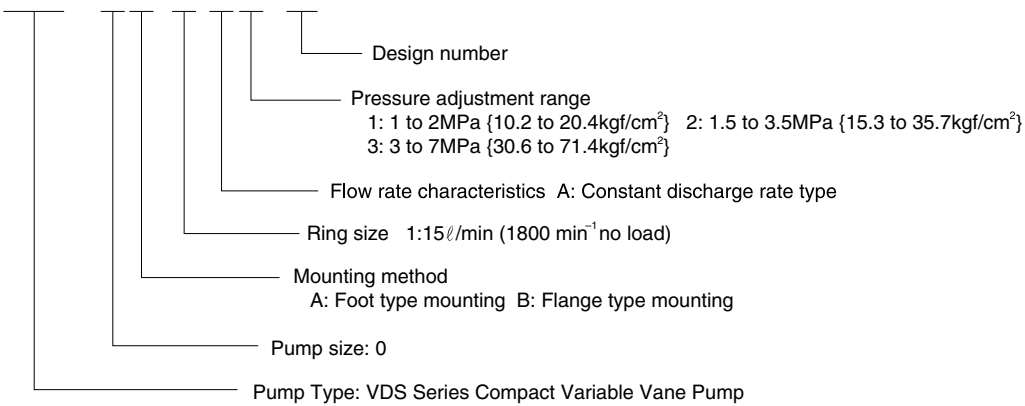

## Installation Dimension Drawings

VDS-0A-1A\*-10

Foot Mounting Type

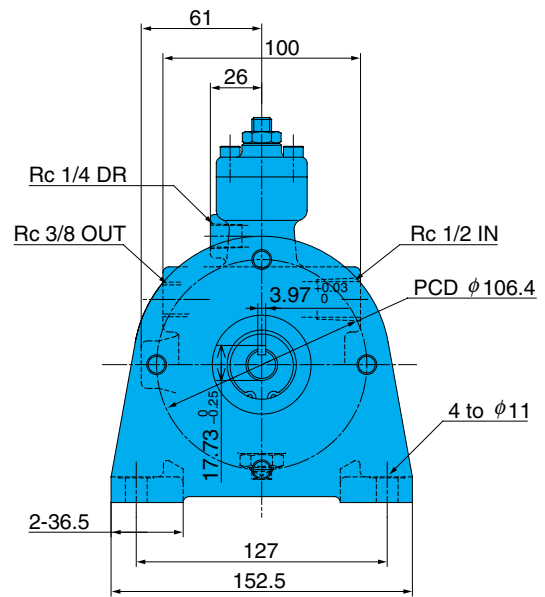
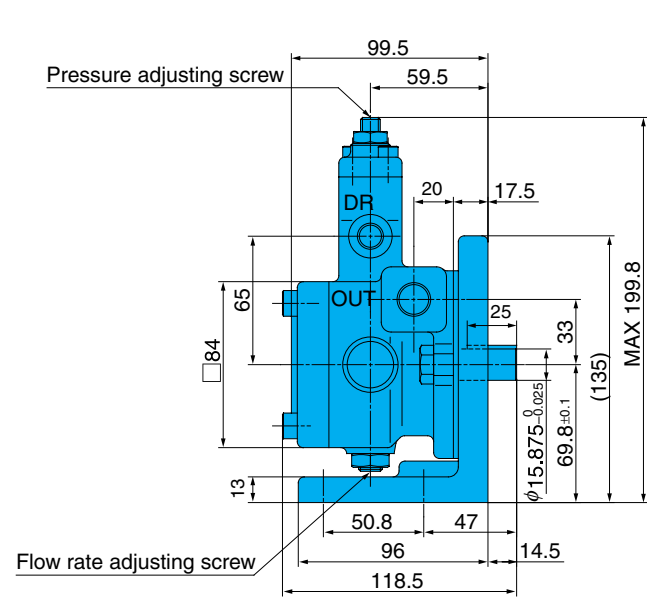

Note) Foot Mounting Kit: IHM-2-10

VDS-0B-1A-\*-10

Flange Mounting

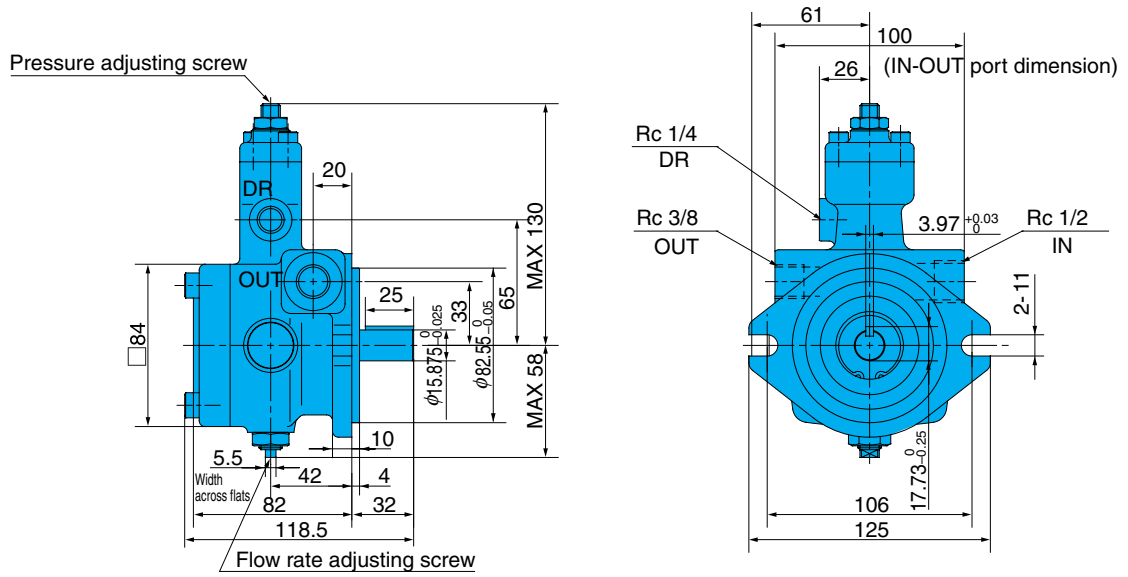

**Performance Curves**

Typical characteristics at hydraulic operating fluid kinematic viscosity of 32 mm<sup>2</sup>/s

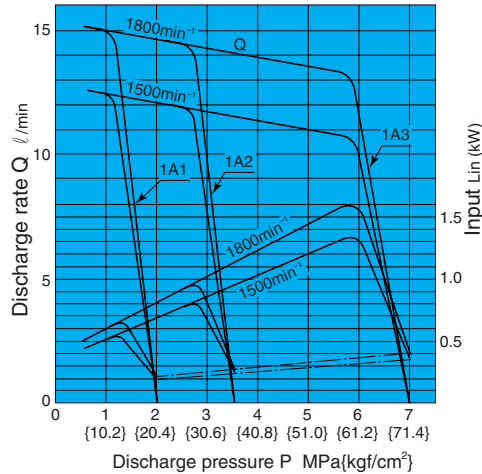

Power Loss Curve – At Full Cutoff

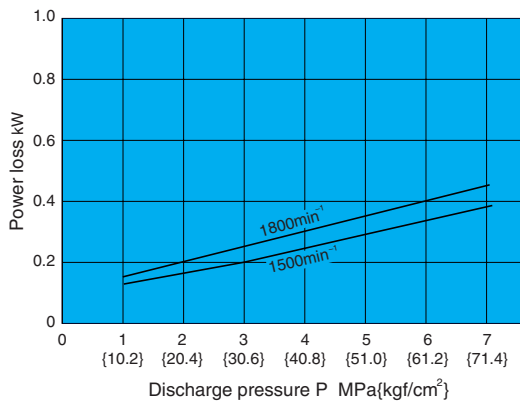

Noise Characteristics

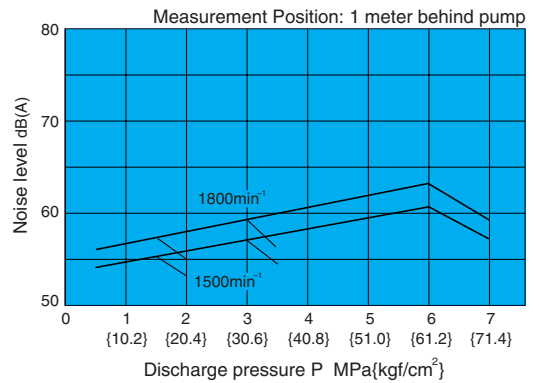

# Cross-sectional Drawing

VDS-0B-1A\*-10

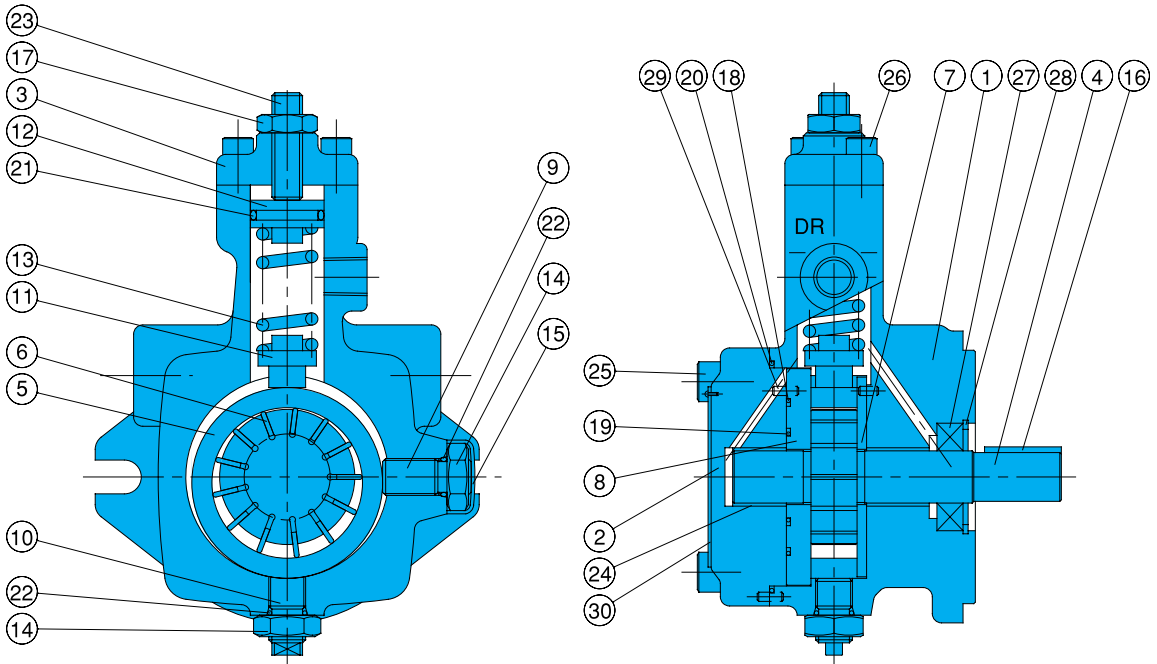

## List of Sealing Parts

Seal Kit: VBAS-100B00

Applicable Pump Model: VDS-0A/B-1A\*-10

Part No.	Part Name	Part Number	Q'ty
18	O-ring	AS568-032	1
19	O-ring	AS568-023	1
20	O-ring	S71 (NOK)	1
21	O-ring	1A-P20	1
22	O-ring	1A-P10	2
27	Oil seal	TC-17358	1

Note)

1.Oil seals are manufactured by Nippon Oil Seal Industry Co. Ltd. (NOK).  
2.O-ring 1A/B-\*\* refers to JIS B2401-1A.

Part No.	Part Name	Part No.	Part Name
1	Body	16	Key
2	Cover (A)	17	Nut
3	Cover (B)	18	O-ring
4	Shaft	19	O-ring
5	Cam ring	20	O-ring
6	Vane	21	O-ring
7	Plate (S)	22	O-ring
8	Plate (H)	23	Screw
9	Thrust screw	24	Bearing
10	Screw	25	Screw
11	Piston	26	Screw
12	Holder	27	Oil seal
13	Spring	28	Snap ring
14	Nut	29	Pin
15	Cap	30	Nameplate

## Uni-pump Specifications

### Understanding Model Numbers

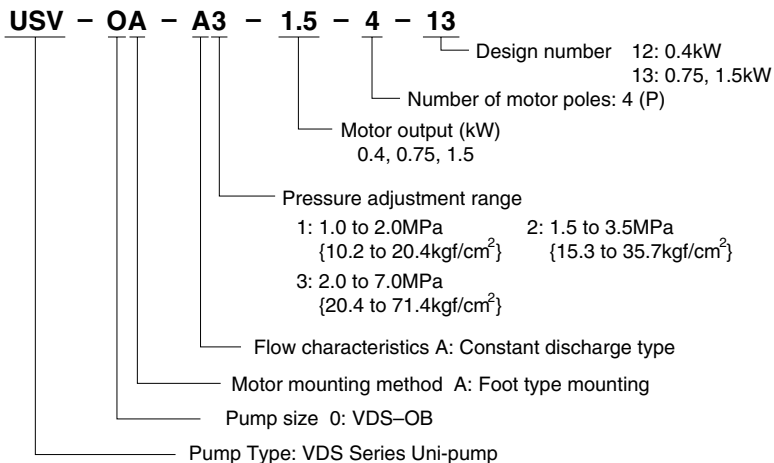

### Specifications

Maximum Working Pressure MPa (kgf/cm <sup>2</sup> )	Maximum Flow Rate ℓ/min	
	50Hz	60Hz
7{71.4}	12.5	15

